

LOC	DIST	F	ZONE	LTR	DESCRIPTION	DATE	APPD
AF	50			E	REV AND REDRAWN PER AF-7225	2/4/91	PF/JR

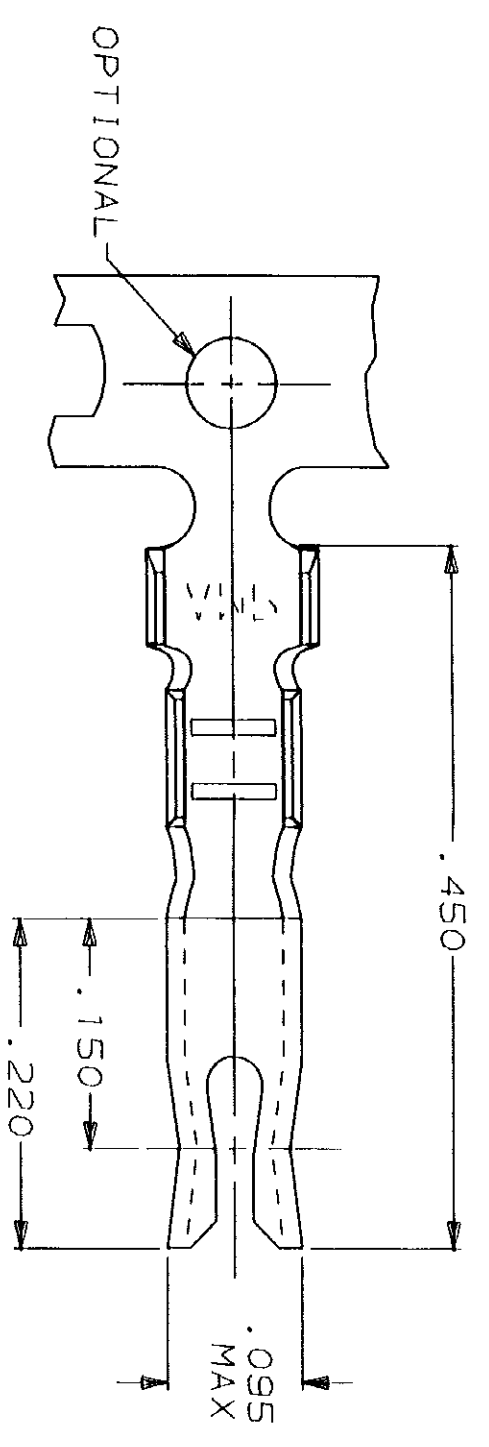

- 1 CONTINUOUS STRIP ON REELS.
- 2 .000030 MIN GOLD PER MIL-G-45204 IN LOCALIZED GOLD PL AREA, GOLD FLASH ON REMAINDER OVER .000050 MIN NICKEL PER QQ-N-290.
- 3 .000080 MIN TIN PL PER MIL-T-10727.

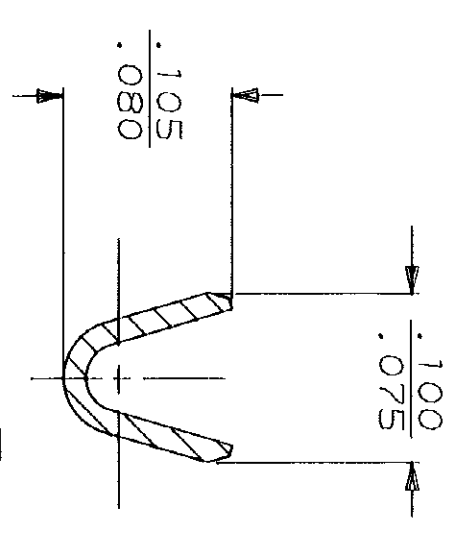
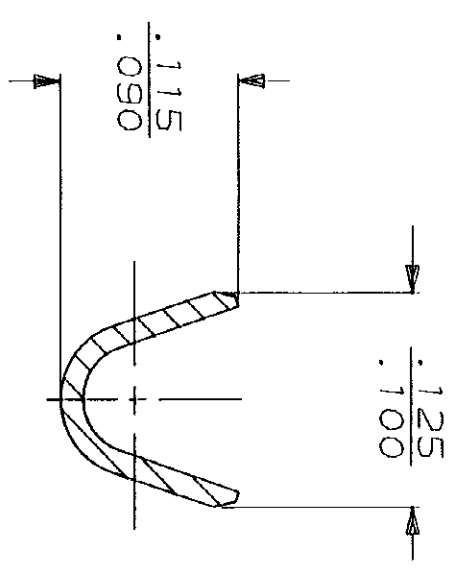
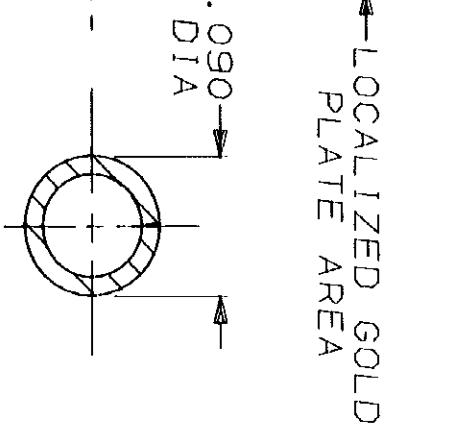
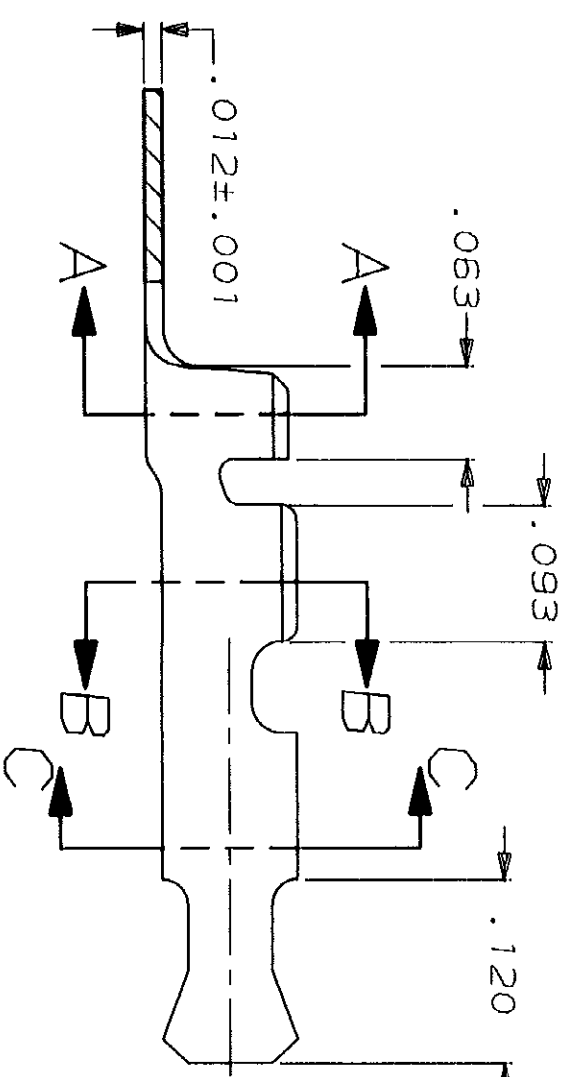

SECTION C-C  
 SECTION A-A SCALE 10:1  
 SECTION B-B SCALE 10:1

FINISH		INSULATION RANGE		WIRE RANGE		PART NO	
3	2	.048-.071	DIA	24-20 AWG		60885-2	60885-1
DO NOT SCALE PRINT. UNLESS SPECIFIED DIMENSIONS IN INCHES TOLERANCES ON:		DR 2/4/91 P FORNEY		NAME		AMP Incorporated	
1 PLC DEC ± .015		CHK 2/4/91 JR RUTH		RECEPTACLE, PIN, .055 DIA		AMP Incorporated	
2 PLC DEC ± .015		APPD 2/4/91 G YETTER		Harrisburg, PA 17105-3608			
3 PLC DEC ± .015		APPD 2/4/91 R WEAVILL					
MATERIAL		PRODUCT SPEC		SIZE		CAGE CODE	
#4 HARD PHOS BRONZE				B		00779	
FINISH		APPLICATION SPEC		DRAWING NO		60885	
SEE TABLE				SCALE		SHEET	
				8:1		1 OF 1	